

Industrial goods

I New Side Mixer



High Quality, Convenient Handling, Easy Maintenance

Simplified design allows for easy handling and maintenance. We developed this New Side (NS) Mixer with technical support from SATAKE Chemical Equipment Mfg., Ltd. We increased the rigidity of the main body of the NS Mixer, suppressing vibrations in the motor. We designed a sight glass for inspection so you can look inside, making inspection and maintenance easy. The NS Mixer acquired the "Type Approval for Safety Product" from the Korea Fire Institute.

Lightweight

The weight also been reduced by 30 ~ 40% and 20 - 30% shorter in length than our belt-driven model

Safety

Acquired "Type Approval for Safety Product"

Mechanical Seal

The design and material used for the NS Mixer's mechanical seal comply with API standards.

Swivel Type

The NS Mixer uses a high rigidity hinge, which allows the impeller to move to the left or right up to 30°
The product offers 24-inch and 30-inch flanges as the standard size

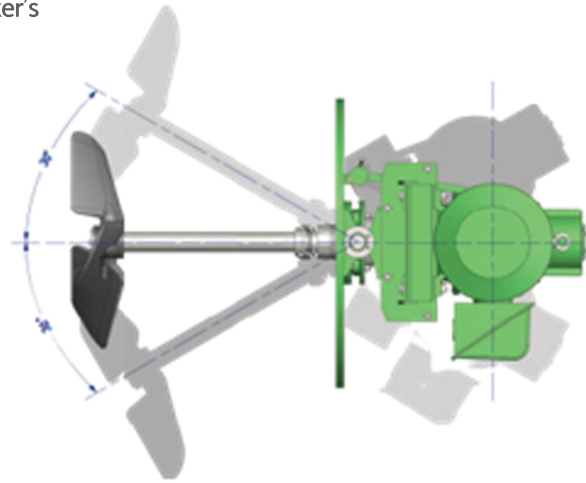

Product Information	
Model	NS Mixer
Rotational Speed	430min
Impeller Diameter	780mm
Discharge Amount	100%

I Company Introduction

Company Name : HADO CO.,LTD.

HADO mixers are the leading products in the industrial fields of petrochemicals and chemicals, pulp and paper, water and waste water treatment, FGD, oil and petroleum, mining and minerals, pharmaceuticals, slurry storage, and many other fluid applications. HADO always make efforts to upgrade the reliability, functionality and safety of the mixers by using flow visualizing methods and advanced CAE methods.

Manager : Taejun OK
E-mail : hado@hado.co.kr
Tel : +82-32-583-6321
Homepage : www.hado.co.kr
Productpage : <https://bitly.co/7rf7>